

**2.0 - All-in-one air conditioning unit with state-of-the-art monobloc technology and no outdoor condenser.**

Product code: C3MO14IC1UC

Model: ..2.0 15HP - 115V/60Hz-1Ph

## BEAUTIFUL, SLIM, AND SILENT

Too often air conditioning means installing bulky and unsightly condensing units outside buildings. The INNOVA **2.0**, however, is an air conditioner without an external unit that is designed to blend seamlessly into existing domestic environments. It delivers excellent energy performance with minimal aesthetic impact.

Every detail of this unit has been fine tuned to create a slim and compact heat pump that delivers on both form and function. In the summer, the **2.0** gives you refreshing cooling and in the winter, cozy heating. Its efficient design also makes it simple to install, requiring little more than two small wall openings.



## General Features

- BLDC Inverter compressor
- ECM fans (centrifugal)
- R32 refrigerant
- Auto restart
- Intelligent defrost
- No outdoor unit
- Condensate disbursement systems
- Onboard touch controller
- Electronically controlled air louver
- 3 selectable fan speeds + Auto
- Easy to install Wi-Fi with Android/iOS App
- Industry leading STC rating
- Modes: Cool, Heat, Dehumidify, Auto
- Dry contact (CP)
- Washable filter
- Cabinet finish: RAL 9003 signal white -steel
- Available: underbody cover plate



## Performance Specifications

### Cooling Performance (35°C: 27°C)

Max. cooling capacity (dual power)		11 500 <sup>(1)</sup>
Performance - cooling - 27°C - max.	BTU/h	10 200
Minimum cooling capacity		3100
Efficiency - cooling - 27°C	SEER2 - EER2	13.65 - 9,14
Airflow - Indoor - Evaporator	CFM	160 to 290
Airflow - Outdoor - Condenser		200 to 350

### Heating Performance (7°C: 20°C)

Max. heat output (dual power)		11 500 <sup>(1)</sup>
Performance - heating max.	BTU/h	10 100
Minimum heat output		3000
Efficiency - heating	HSPF2	7,00
Nominal sound pressure	dB(A)	41
Minimum sound pressure		27

<sup>(1)</sup> DUAL POWER - DC Inverter technology provides a capacity boost up to 11 500 btu/h

# Electric Specifications (Power Supply = Hardwired Only)

<b>Volt range</b>		<b>V</b>	103 to 127
<b>Tension power supply</b>		<b>V / Hz / ph</b>	115 / 60 / single phase
<b>Power factor</b>		<b>%</b>	0.96
<b>Cooling</b>	<b>Nonimal</b>	<b>A</b>	7,7
	<b>Max</b>		8,8
<b>Heating</b> <small>(heat pump only)</small>	<b>Nonimal</b>		6,3
	<b>Max</b>		8,8
<b>Circuit breaker</b>	<b>MCA</b>		13
	<b>MCOP</b>		25
	<b>Recommend size</b>	15	

## ALL UNITS COME WITH

Heat exchangers, DC Inverter compressor, condensate release system with summer evaporation, EC fan on outdoor side and DC brushless fan, Wi-Fi connectivity, R32 gas - no power cord is provided.



## Dimensions - Physical Data

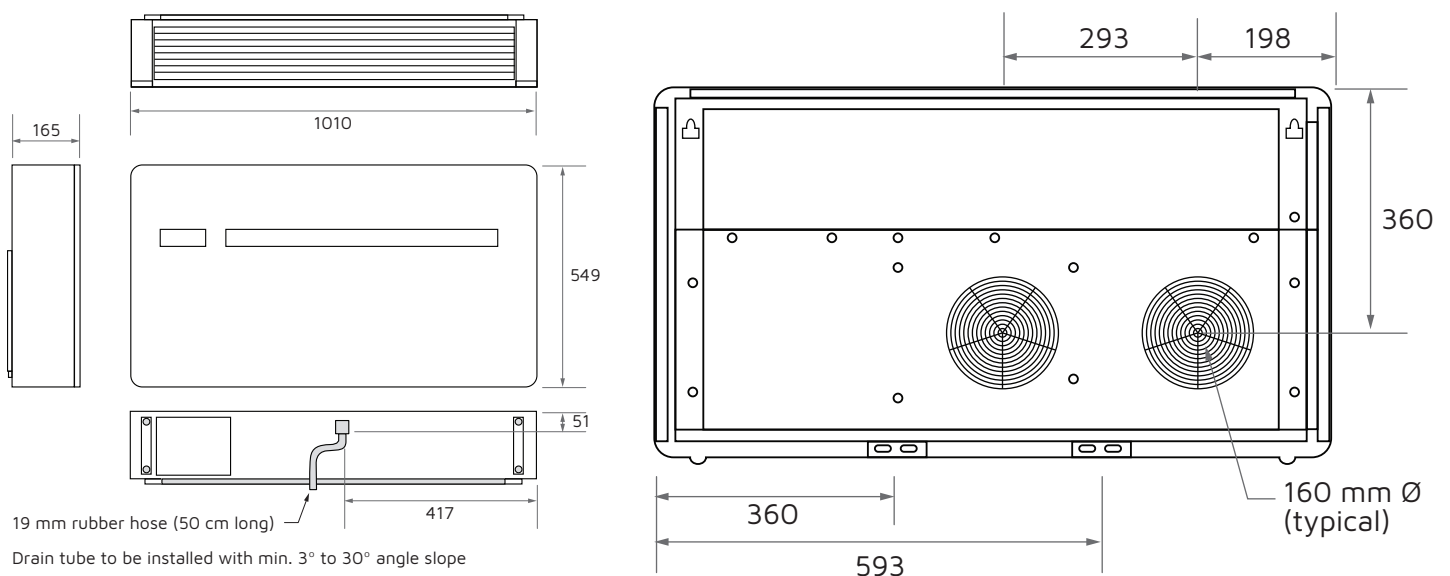

# Installation clearance

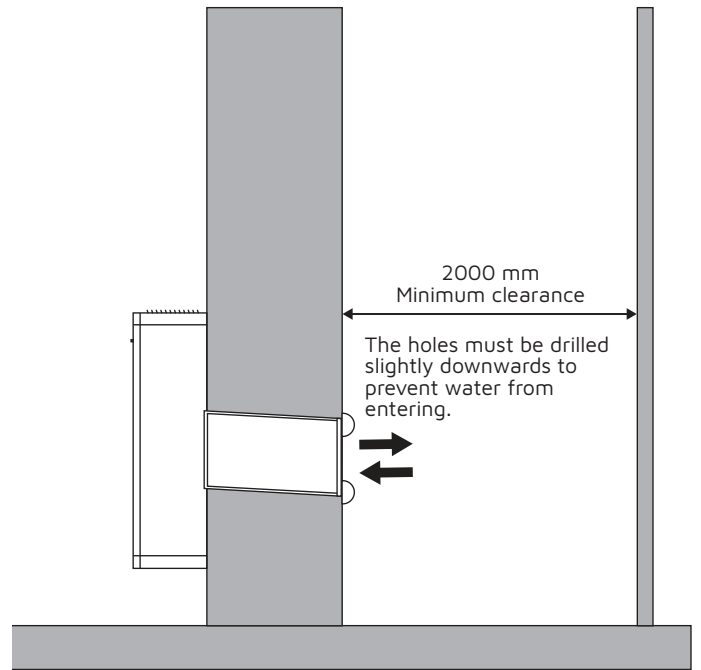
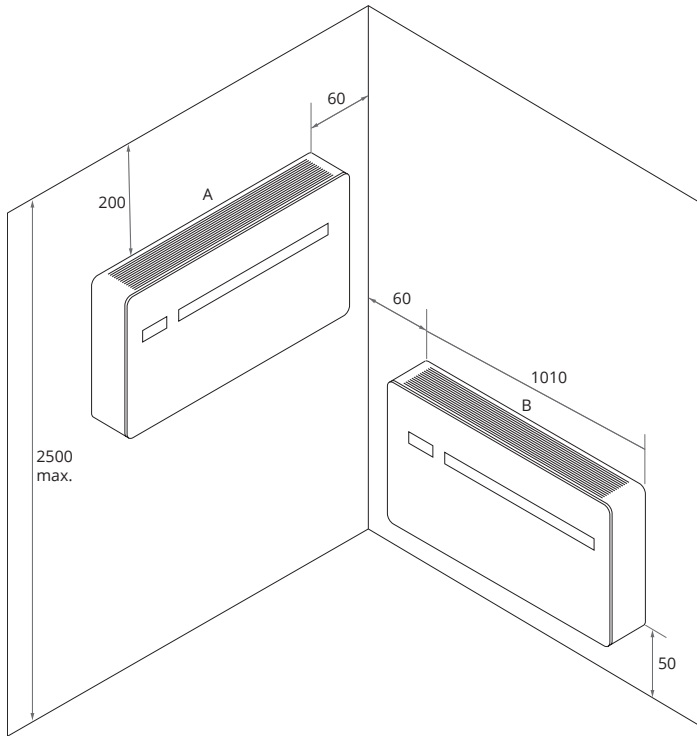

# Mounting template

- For the unit to work, two holes with a 162 mm diameter must be placed as indicated on the template.
- The maximum depth of the holes is 1 m and there must be no bends.
- Use the supplied grids or grids with the same characteristics.

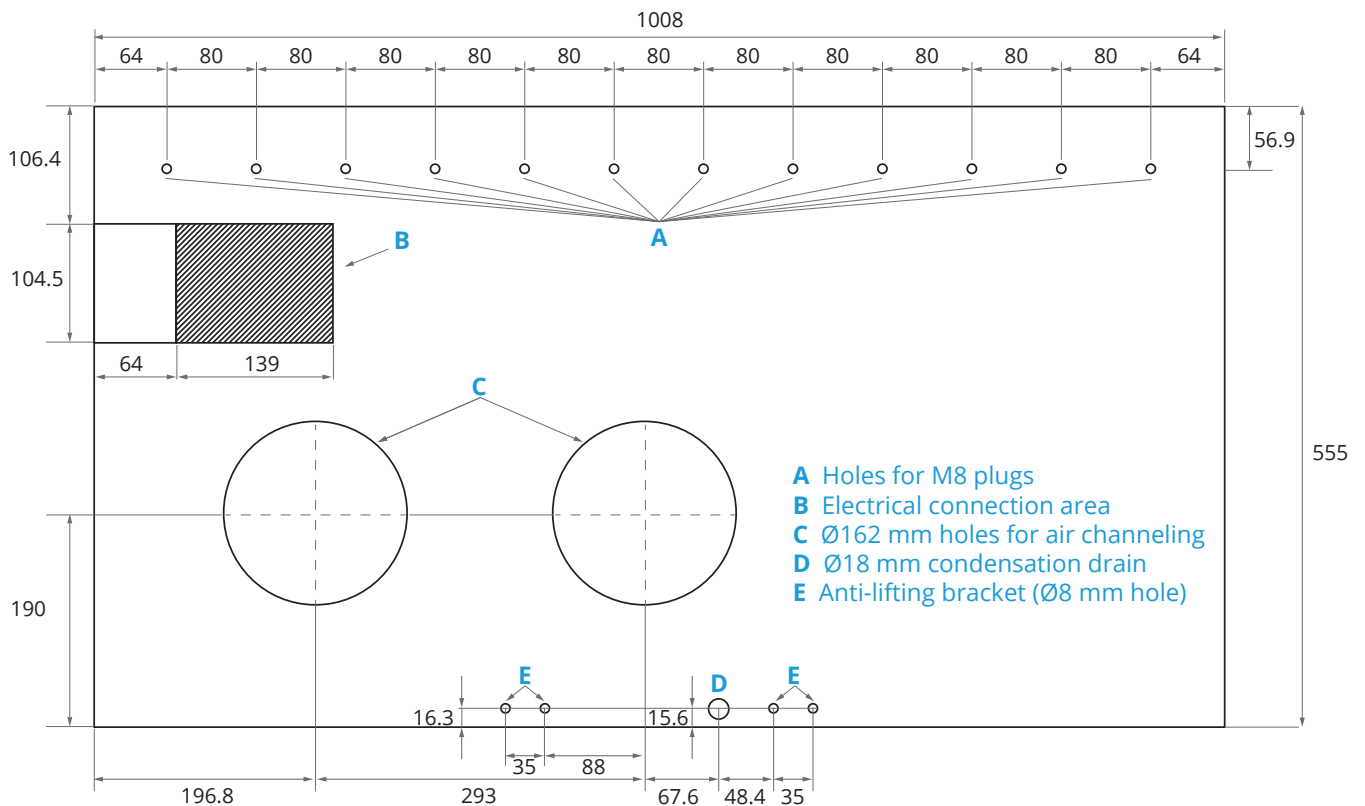

## Heating performance (based on variable temperature)

Indoor Temp. (°C)	Maximum Fan Speed			Minimum Fan Speed		
	20			20		
Outdoor Temp. (°C)	PH	PA	COP	PH	PA	COP
-20	1,21	0,66	1,83	0,64	0,33	1,95
-10	1,25	0,66	1,89	0,67	0,33	2,02
-7	1,52	0,68	2,24	0,81	0,34	2,38
-2	1,85	0,69	2,68	0,98	0,35	2,85
2	2,09	0,70	2,99	1,11	0,35	3,18
7	2,31	0,71	3,25	1,23	0,36	3,46
12	2,62	0,71	3,68	1,39	0,36	3,91
15	2,78	0,71	3,90	1,48	0,36	4,15
20	3,10	0,72	4,31	1,65	0,36	4,58



## Cooling performance (based on variable temperature)

Indoor Temp. (°C)	Maximum Fan Speed						Minimum Fan Speed					
	25			27			25			27		
Outdoor Temp. (°C)	PC	PA	COP	PC	PA	COP	PC	PA	COP	PC	PA	COP
40	2,16	0,78	2,77	2,22	0,78	2,85	1,12	0,39	2,87	1,14	0,40	2,85
38	2,22	0,75	2,96	2,28	0,75	3,04	1,17	0,37	3,16	1,19	0,38	3,13
35	2,27	0,72	3,15	2,33	0,72	3,24	1,22	0,35	3,49	1,24	0,36	3,44
27	2,30	0,70	3,29	2,36	0,70	3,37	1,25	0,33	3,79	1,27	0,34	3,74
25	2,33	0,68	3,43	2,39	0,68	3,51	1,28	0,31	4,13	1,30	0,32	4,06
23	2,36	0,66	3,58	2,42	0,66	3,67	1,31	0,29	4,52	1,33	0,30	4,43
20	2,39	0,64	3,73	2,45	0,64	3,83	1,34	0,27	4,96	1,36	0,28	4,86
18	2,42	0,62	3,90	2,48	0,62	4,00	1,37	0,25	5,48	1,39	0,26	5,35

PH = Heating capacity (kW)

PC = Cooling capacity (kW)

PA = Input power (kW)

\* Outdoor relative humidity = 85 %

## Installation notes

- The unit must be perfectly level on the vertical and horizontal axis.
- The unit must be tight to the wall, with zero leakage between the external ducts and the unit. Use insulating material if wall is not level.

## REAR

- The rear of the unit must be tight to the wall so there are zero gaps between the wall and the unit,
- Gaps can allow outside air inside and create short cycling and humidity. If there are any gaps, they must be sealed with insulation.

## EXTERIOR

- On the exterior of the building, there should be no obstacles blocking the airflow from the louver. There must be a least 100 cm of free and clear space in front of the louvers.

## RETURN AIR

- The return air is on the top through the integrated return air grille.



Innova is constantly innovating and improving its products and reserves the right to modify product design and specifications without notice and without incurring any obligations.